

Profile	Label	#	Description
	001	2	1/4" ALUMINIUM OVAL BASE PLATE 17.5" (444.5MM) x 4.72" (120MM)
	002	1	M1901 36" (914.4MM) EXTRUSION W/ (2) 45° CUTS, (4) HOLES FOR BASE PLATE & LIGHTS
	003	1	M1901 47.5" (1206.5MM) EXTRUSION W/ (1) 45° CUT
	004	1	M1901 47.5" (1206.5MM) EXTRUSION W/ (1) 45° CUT
	005	1	M1901 47.5" (1206.5MM) EXTRUSION W/ (1) 45° CUT, PLASTIC EXTR. & POWER SUPPLY
	006	1	M1901 47.5" (1206.5MM) EXTRUSION W/ (1) 45° CUT & PLASTIC EXTR.
	007	1	M1901 36" (914.4MM) EXTRUSION W/ (2) 45° CUTS & LIGHTS
	008	1	Z4400 34.75" (882.7MM) EXTRUSION W/ (2) LOCKS
		8	Z966 90° CORNER INTERNAL CONNECTOR
		4	Z967 STRAIGHT INTERNAL CONNECTOR
		4	5/16-18 FLAT HEAD SCREW 0.75" LONG FOR BASE PLATES
		2	35.5"W (908MM) x 94.5"H (2400MM) SINGLE SIDED DYESUB GRAPHIC W/ SEG WELT ALL 4 SIDES

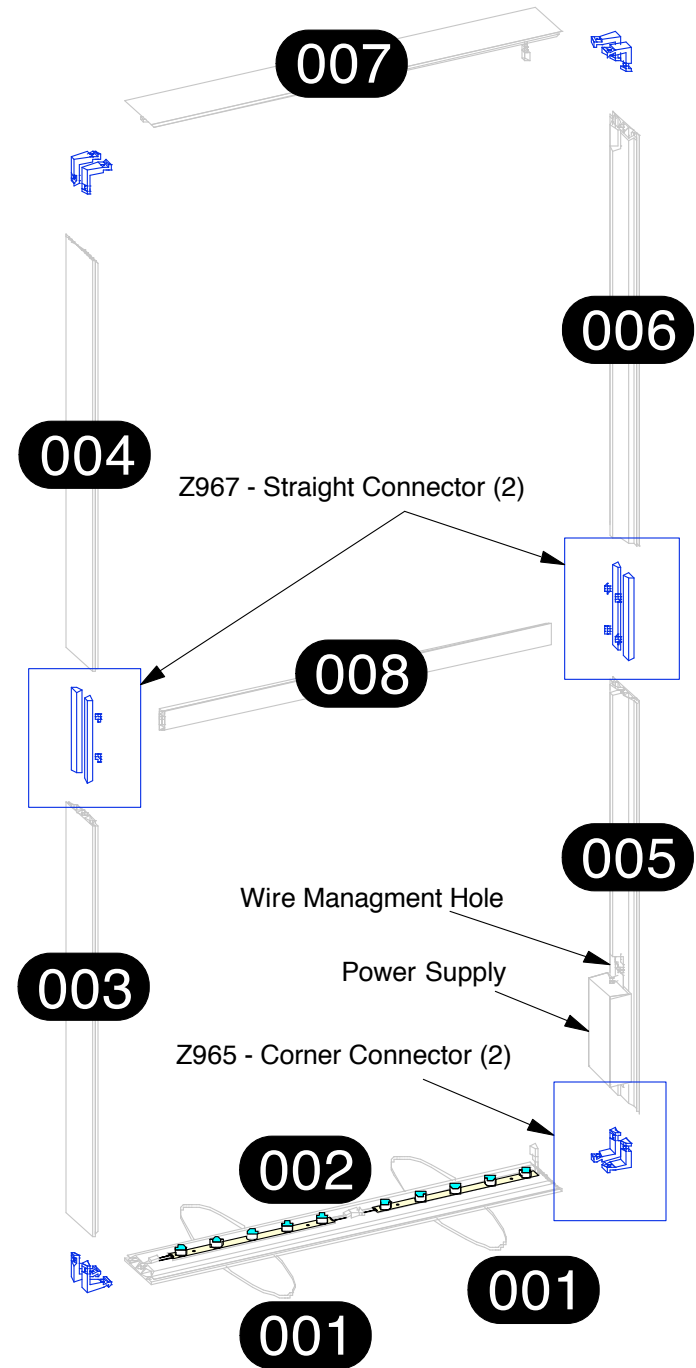

1. Slide straight connector (Z967) into inner channel of extrusion. Turn screw enough to hold connector in place.
2. Take another extrusion and slide onto straight connector. Tighten both screws to connect extrusions together.
3. Repeat above steps to connect all spliced extrusions together.
4. Slide corner connector (Z965) into both sides of horizontal extrusions. Turn each screw enough to hold connector in place.
6. Slide vertical extrusions onto corner connectors of top horizontal extrusion. Turn each screw enough to hold connector in place.
7. Finish frame assembly by sliding corner connectors of bottom horizontal extrusion into inner channel of vertical extrusions and tighten the screws to secure frame extrusions together.

Bottom view

Loosen the screws on base plate but do not remove them. Then swivel base plates.

Bottom view

Tighten both screw firmly.

Z965 - Corner Connector

Connect frame extrusions together, as shown, using Torx tool (included). Do not overtighten.

NOTE: Remove corner connectors from extrusions before packing

Z967 - Straight Connector

Connect frame spliced extrusions together, as shown, using Torx tool (included). Do not overtighten.

NOTE: Remove connectors from beams before packing

GRAPHIC

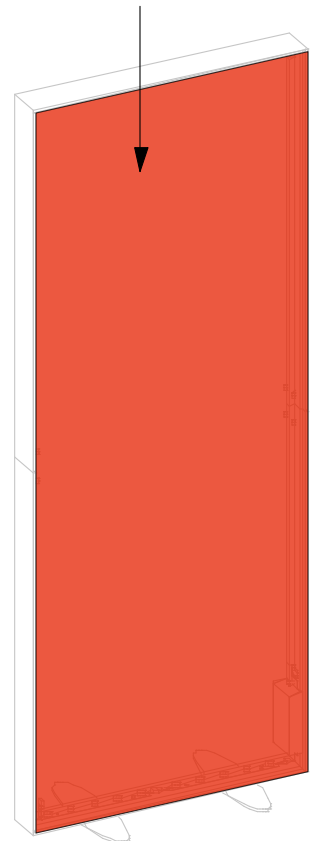

3D VIEW

GRAPHIC

Extrusion fabric groove

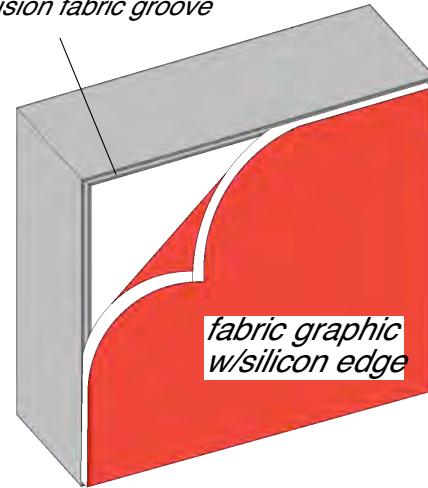

fabric graphic w/silicon edge

Insert the silicon edge of the fabric into the groove of the extrusions.

Start on the corners, than centers and work your way to corners from center on both directions.

To pull fabric graphic out of extrusion groove use pull tab on corner.

PACKING DIAGRAM

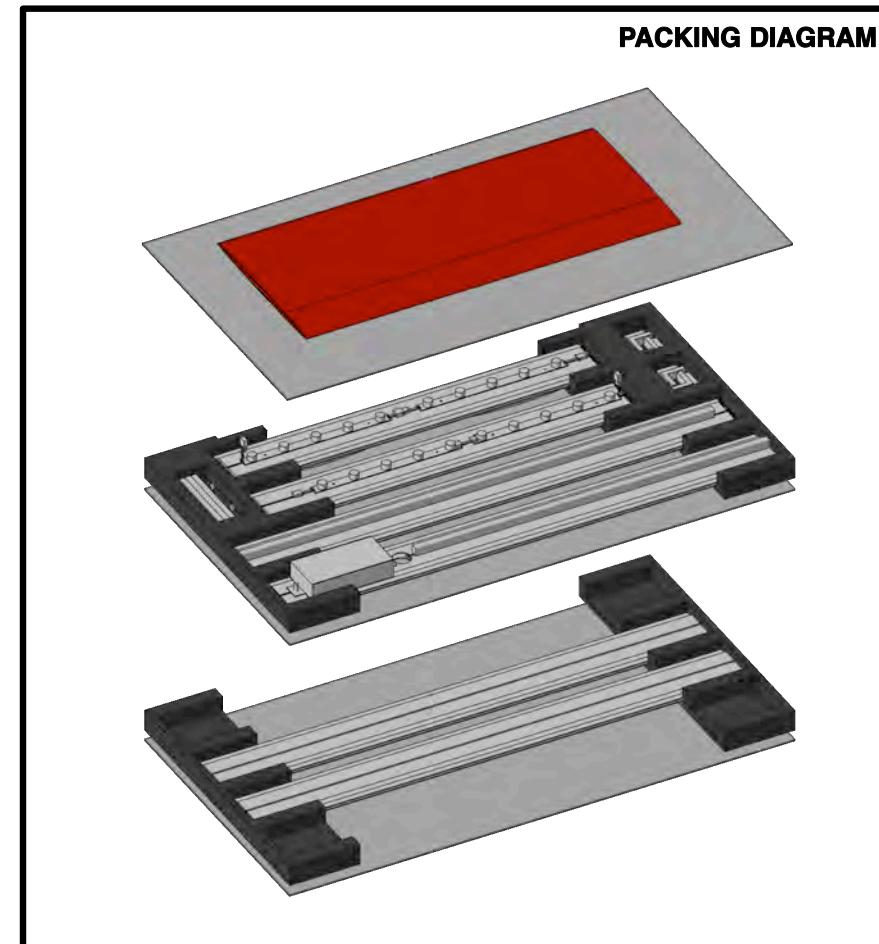

**NOTE:
DO NOT DISCARD
ANY PACKING
MATERIAL.
LEVELS OF PARTS
MAY BE
SEPARATED BY
WHITE SHEETS OF
PLASTIC,
COROPLAST OR
CARDBOARD.**

LIGHTS DETAILS

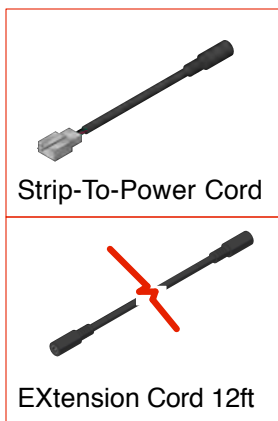
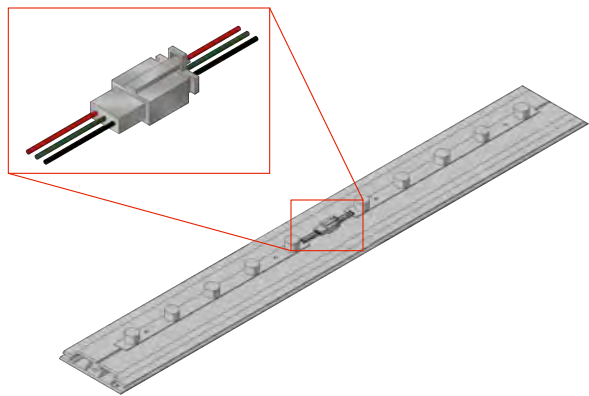

Lights come attached to extrusions. Ensure all lighting strips are connected. Once frame is assembled, connect strip-to-power cords to the end of top and bottom lights chain.

- For bottom lights connect strip-to-power cord to power supply directly.
- For top lights connect extension cord to strip-to-power cord and run with wire management extrusion then connect to power supply.

Run AC power cord out through grommet hole on vertical upright and connect to power outlet.

To remove or re-attach light strips use provided thumbscrews with plate.

WALL ASSEMBLY (OPTIONAL)

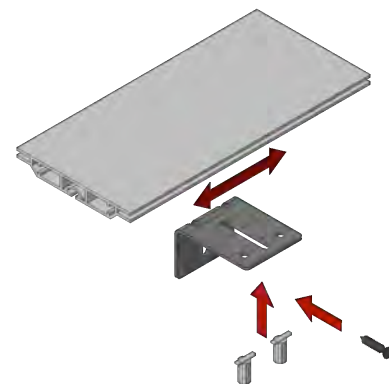

Attach wall bracket to top extrusion groove with provided hammerhead screws. Locate position of wall bracket on extrusion (preferably by wood stud) by sliding the bracket on the extrusion and tighten it. Secure the frame to the wall with provided wood screw.

