

**FRONT VIEW**

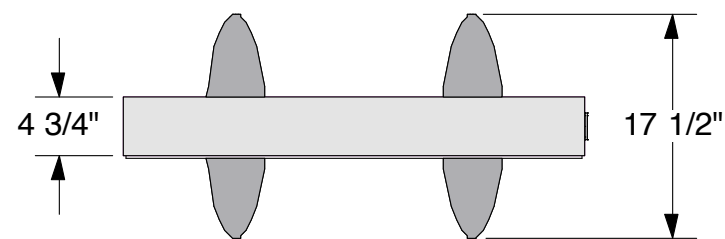

**TOP VIEW**

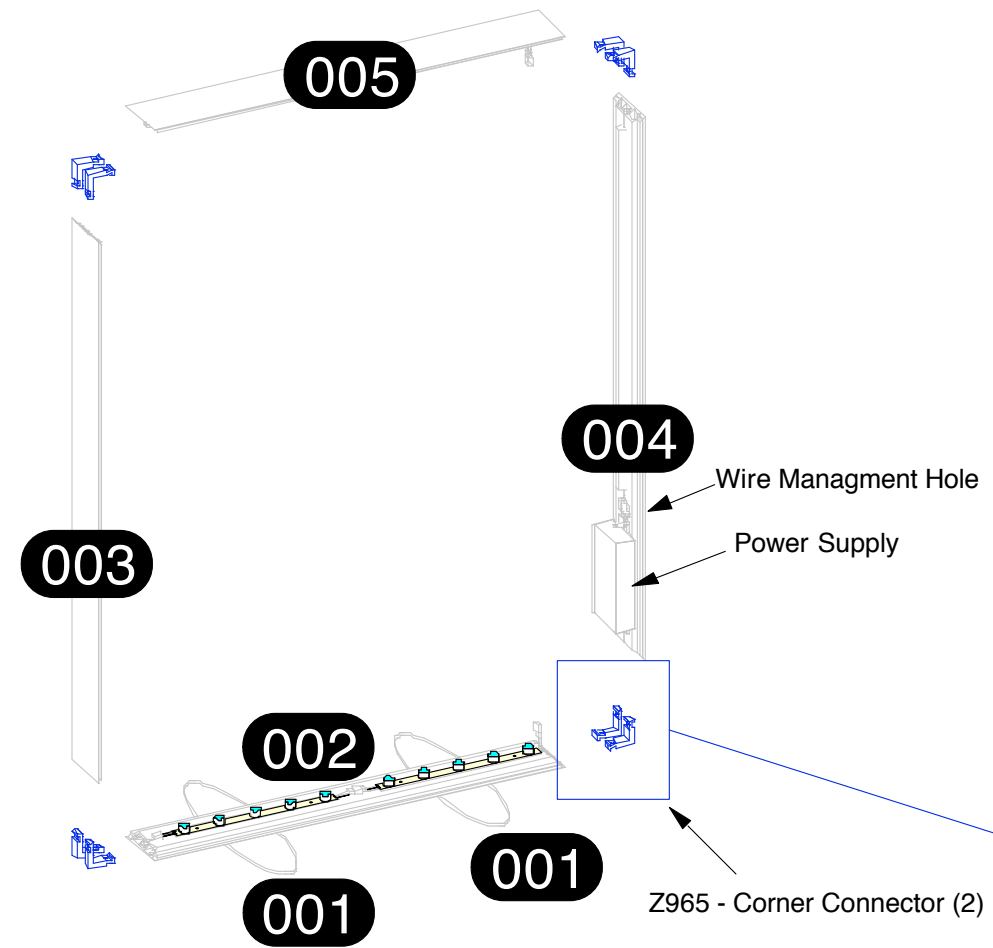

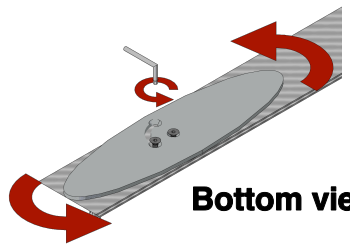

**Bottom view**

Loosen the screws on base plate but do not remove them. Then swivel base plates.

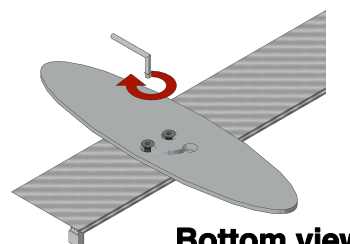

**Bottom view**





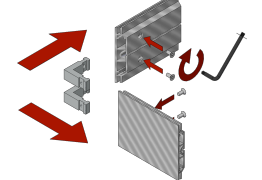

Tighten both screw firmly.

**Z965 - Corner Connector**

Connect frame extrusions together, as shown, using Torx tool (included). Do not overtighten.



*NOTE: Remove corner connectors from extrusions before packing*

Profile	Label	#	Description
	<b>001</b>	2	1/4" ALUMINIUM OVAL BASE PLATE 17.5" (444.5MM) x 4.72" (120MM)
	<b>002</b>	1	M1901 36" (914.4MM) EXTRUSIONS W/ (2) 45° CUTS, (4) HOLES FOR BASE PLATE & LIGHTS
	<b>003</b>	1	M1901 47.5" (1206.5MM) EXTRUSIONS W/ (2) 45° CUTS
	<b>004</b>	1	M1901 47.5" (1206.5MM) EXTRUSIONS W/ (2) 45° CUTS & POWER SUPPLY
	<b>005</b>	1	M1901 36" (914.4MM) EXTRUSIONS W/ (2) 45° CUTS & LIGHTS
		8	Z966 90° CORNER INTERNAL CONNECTOR
		4	5/16-18 FLAT HEAD SCREW 0.75" LONG FOR BASE PLATES
		2	35.5"W (908MM) x 47"H (1194MM) SINGLE SIDED DYESUB GRAPHIC W/ SEG WELT ALL 4 SIDES

- Slide corner connectors (Z965) into both sides of horizontal extrusions. Turn each screw enough to hold connector in place.
- Slide vertical extrusions onto corner connectors of top horizontal extrusion. Turn each screw enough to hold connector in place.
- Finish frame assembly by sliding corner connectors of bottom horizontal extrusion on to vertical extrusions and tighten the screws to secure frame extrusions together.

**GRAPHIC**

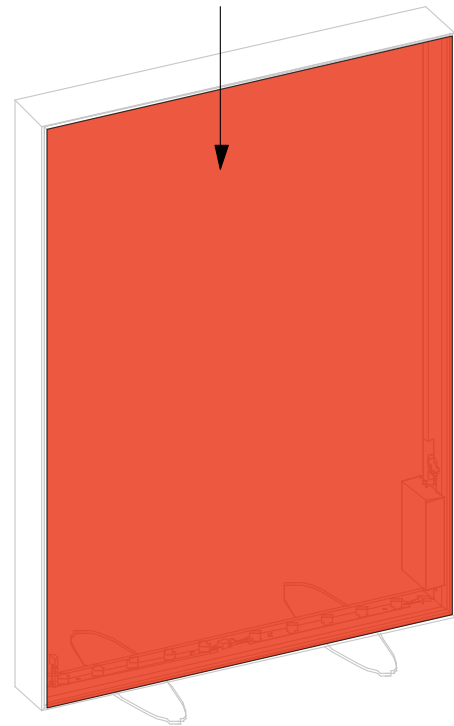

**3D VIEW**

**GRAPHIC**

*Extrusion fabric groove*

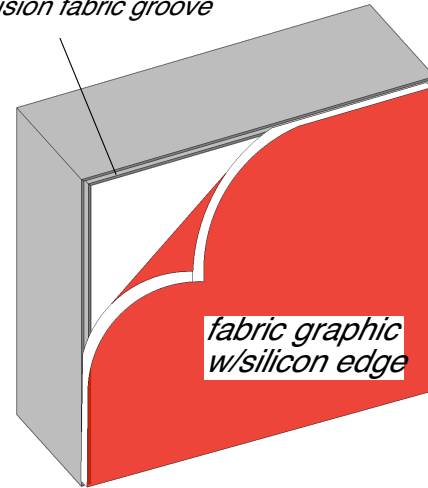

*fabric graphic w/silicon edge*

Insert the silicon edge of the fabric into the groove of the extrusions.

Start on the corners, than centers and work your way to corners from center on both directions.

To pull fabric graphic out of extrusion groove use pull tab on corner.

**PACKING DIAGRAM**

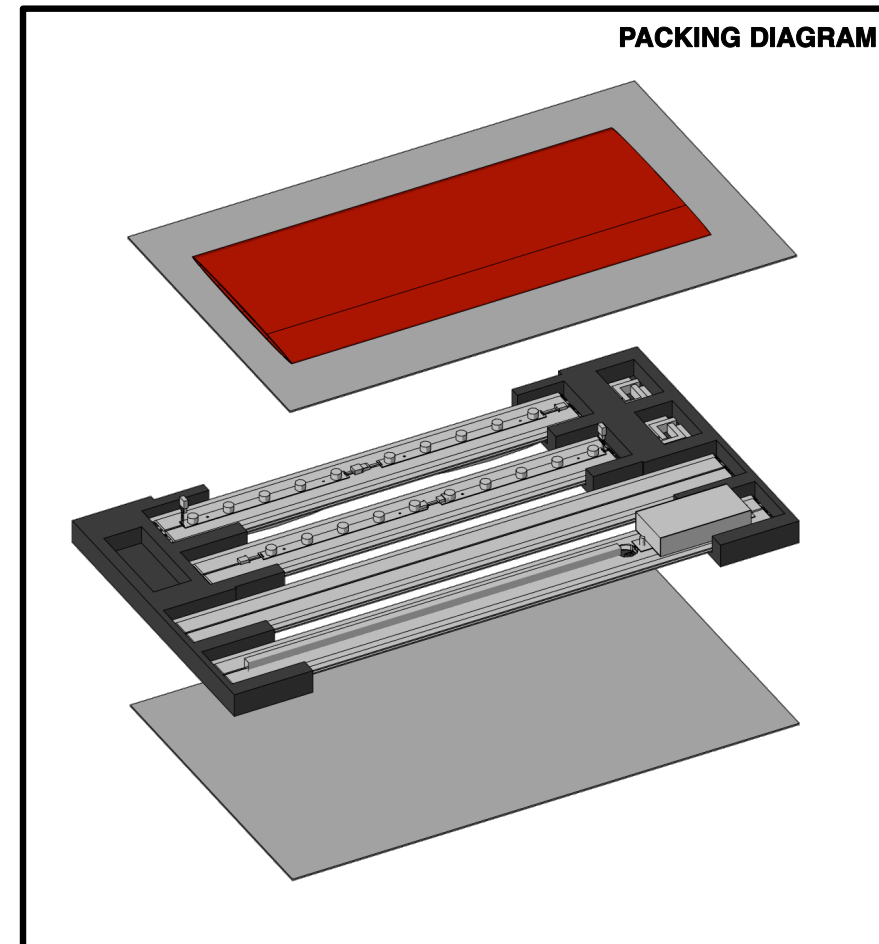

**NOTE:  
DO NOT DISCARD  
ANY PACKING  
MATERIAL.  
LEVELS OF PARTS  
MAY BE  
SEPARATED BY  
WHITE SHEETS OF  
PLASTIC,  
COROPLAST OR  
CARDBOARD.**

**LIGHTS DETAILS**

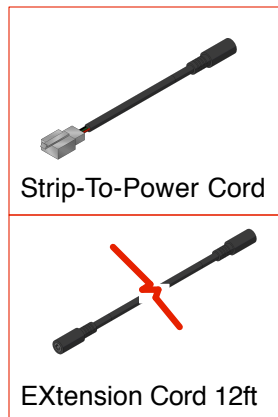
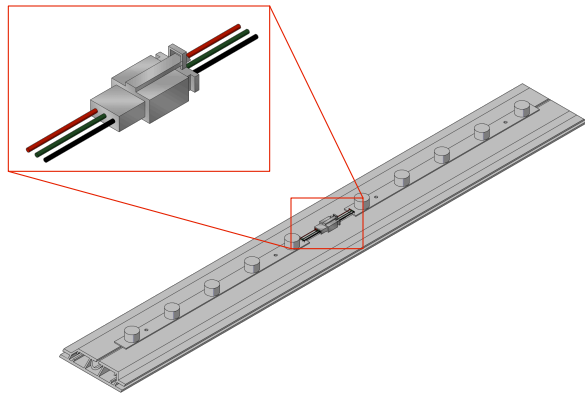

Lights come attached to extrusions. Ensure all lighting strips are connected. Once frame is assembled, connect strip-to-power cords to the end of top and bottom lights chain.

- For bottom lights connect strip-to-power cord to power supply directly.
- For top lights connect extension cord to strip-to-power cord and run with wire management extrusion then connect to power supply.

Run AC power cord out through grommet hole on vertical upright and connect to power outlet.

To remove or re-attach light strips use provided thumbscrews with plate.

**WALL ASSEMBLY (OPTIONAL)**

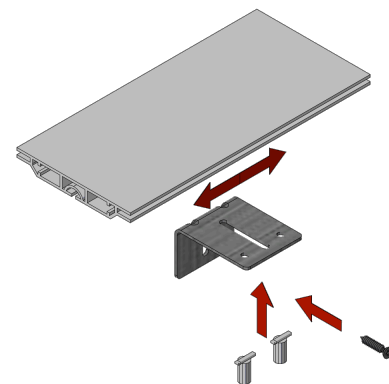

Attach wall bracket to top extrusion groove with provided hammerhead screws. Locate position of wall bracket on extrusion (preferably by wood stud) by sliding the bracket on the extrusion and tighten it. Secure the frame to the wall with provided wood screw.

